

RSH Series

SPECIAL BOILER FOR HEAT PUMP

RUSH brand heat pump boilers, with AISI 316L (1.4404) stainless steel coils, produce hygienic water while also serving as a buffer tank for heat pump devices. A different heat source can be connected to the heat pump boilers to support the system's heat pump.

RSH model devices are recommended for inverter and On/Off heat pumps.

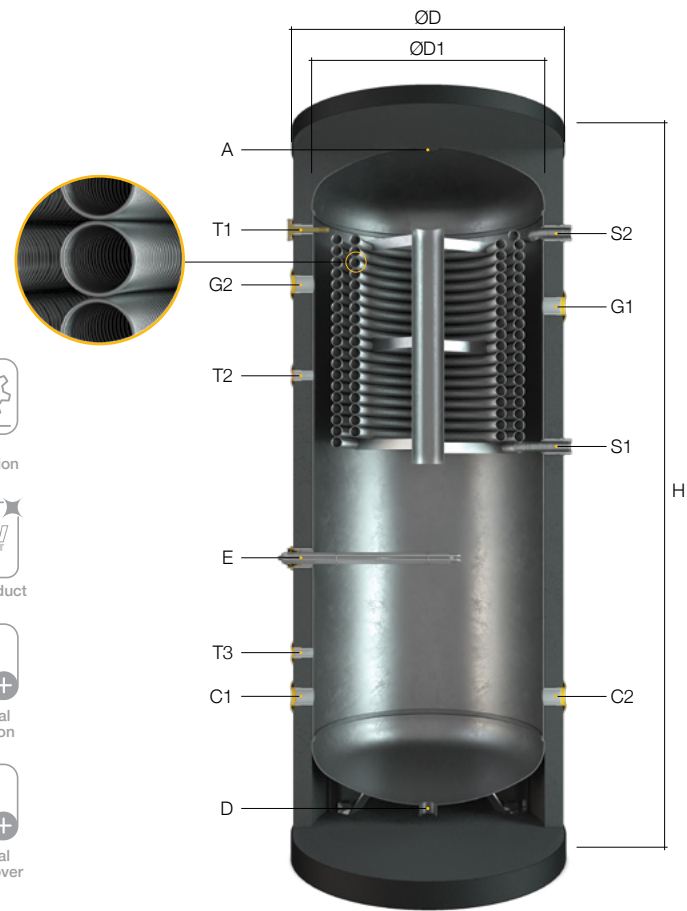

RSH Series Technical Specifications

PRODUCT CODE		RSA160	RSA200	RSA300	RSA500	
Volume	lt	160	200	300	500	
ØD1	Inner Diameter	mm	480	480	480	640
ØD	Outer Diameter	mm	580	580	580	740
H	Tank Height (± 30mm)	mm	1116	1276	1826	1896
A	Air Vent	inch	1/2"			
T	Thermo. & Sensor Connection	inch	1/2"			
S1/S2	DHW Coil Inlet-Outlet Connect.	inch	1"			
C	Cold Water Inlet-Outlet Connect.	inch	1 1/4"			
D	Drainage	inch	1 1/4"			
G	Hot Water Inlet-Outlet Connect.	inch	1 1/4"			
E	Electric Resistance Connection	inch	2"			
Steel Feeler Sleeve		STD / 100 mm X 3 pcs				
Thermometer (0 - 120°C)		STD / Ø63 mm				
Design Pressure	bar	10				
Test Pressure	bar	13				
Max. Operating Pressure	bar	10				
Max. Water Temperature	°C	95				
Coil Material	AISI 316L (1.4404)					
Insulation Type & Thickness	STD - 50mm Elastomeric Rubber (42 kg/m³)					
	OP - 50 mm Soft PU (18 kg/m³)					
	OP - 80 mm Soft PU (18 kg/m³)					
Outer Cover	STD - XLPE Cross-linked Polyethylene					
	OP - Artificial Leather					
	OP - Acrylonitrile Butadiene Styrene (ABS)					
Outer Cover Color	RAL 9005 - RAL 7016					

STD: Standard Hardware OP: Optional Hardware